



CB 246

LIST OF THE EXPLODED VIEWS



SHELL ASSY

COOLING SYSTEM

HYDRAULIC CIRCUIT

ELECTRIC PARTS

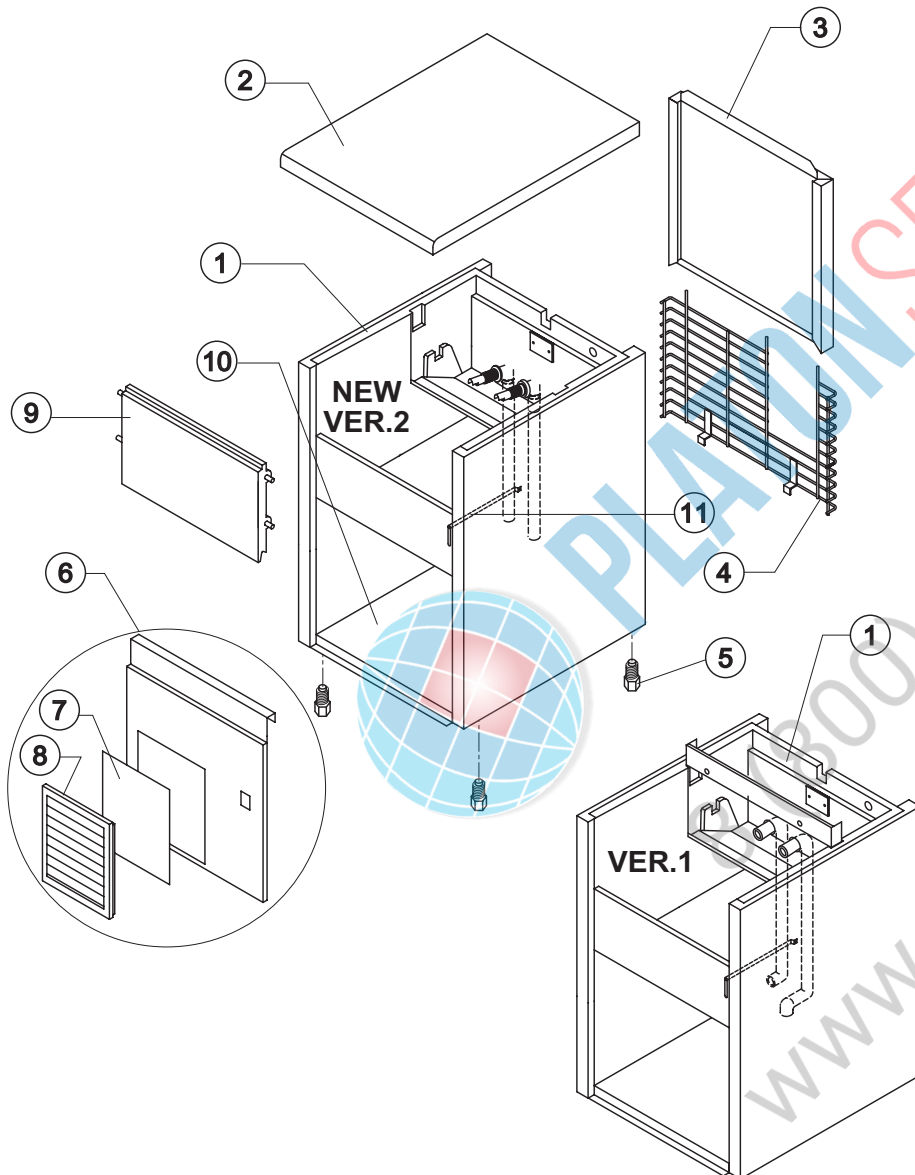

Ref.	Spare Description	Code
1	Foamed Cabinet Assy	See Table -
2	Top Assembly	C22693
3	Rear Panel Assembly	C21180
4	Rear Grid	D12002
5	Foot	10017
6	Front Grid Panel	Current Version C22502
6	Front Panel	Till s/n 28877 22004
7	Filtering Panel	18106
8	Frame + Grid & Filter	C10205
9	Door Assembly	C10303
10	Base Plate	21001
11	Bulb-holder Pipe	20520

Rev. 6 - 24/07/2007

Ref. 1 - Foamed Cabinet Assy Version 1	
Kind of Cube	Code
18 g. (Standard)	C11002/E
33 g.	C11002/E
13 g.	C11002/ED

Ref. 1 - Foamed Cabinet Assy Version 2	
Condensation	Code
Air	RC11002A
Water	RC11002W



CB 246

COOLING SYSTEM

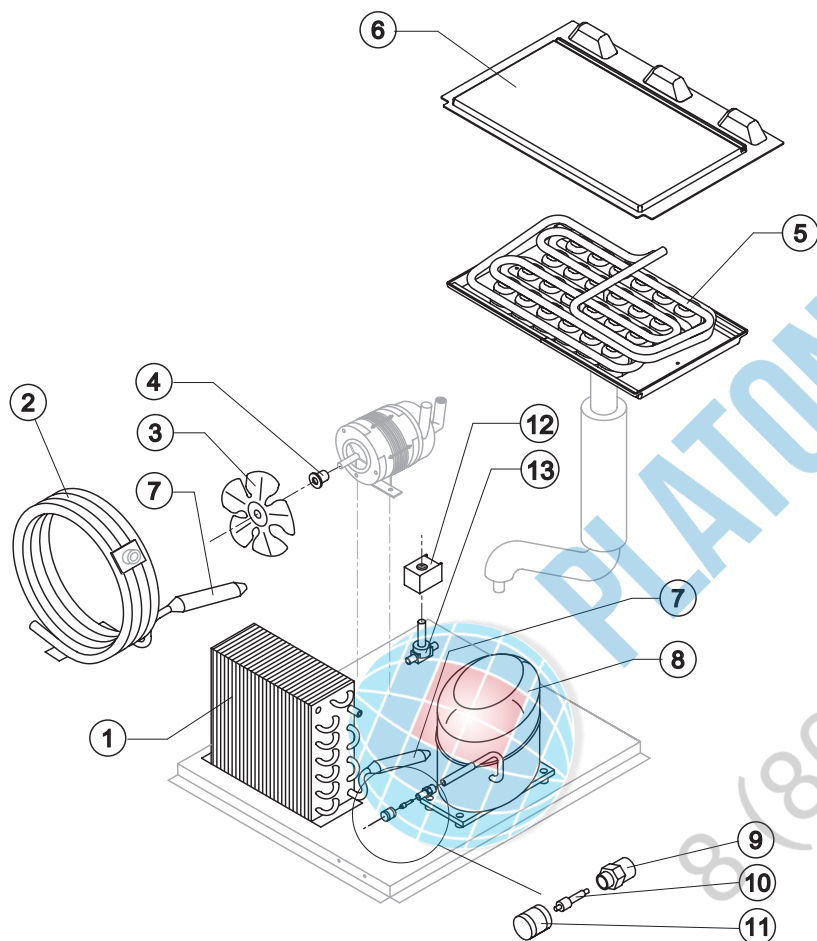

Common Parts

Ref.	Spare Description	Code
3	Sucking Fan	10213
4	Fan Fixing Hub	10014
5	Evaporator	See Table
6	Evaporator Cover Panel	Current Version
6	Evaporator Cover Panel	Till s/n. 225081
7	Molecular Drier	14009
8	Compressor	See Table
9	Vacuum-Charge Valve Body	14007
10	Vacuum-Charge Valve Device	14005
11	Vacuum-Charge Valve Plug	14006
12	Hot Gas Valve Coil	See Table
13	Hot Gas Valve Body	20410

Parts For Air-Cooled Version Only

Ref.	Spare Description	Code
1	Air Condenser	Current Version
1	Air Condenser	Till s/n 104676

Parts For Water-Cooled Version Only

Ref.	Spare Description	Code
2	Water Condenser	Current Version
2	Water Condenser	Till s/n 28525

Ref. 5 - Evaporator

Kind of Cube	Code
18g. (Standard)	D10045
33 g.	D10320
13 g.	D10416

Ref. 8 - Compressor

Tension	Code
T11	23436
T12	23494
T13	23446
T19	23446

Ref. 12 - Hot Gas Valve Coil

Tension	Code
T11	23091
T12	23091
T13	23256
T19	23256

Rev. 6 - 24/07/2007



CB 246

HYDRAULIC CIRCUIT

Common Parts

Ref.	Spare Description	Code
1	Ice Cubes Slide	See Table -
3	Panel with Flags	Till s/n. 379503 C22034
4	Sprayers Bar Assembly	See Table -
5	Sprayer	D20002
6	Sprayer Bar Plug	10012
7	Overflow Cap	10305
8	Overflow Pipe	10133
9	OR Gasket for Overflow Pipe	20233
10	Inner Basin	10252
11	Semirigid Polyethylene Gasket	13007
12	Bin Discharge Nut	10096
13	Overflow Pipe	Current Version 13105
13	Overflow Pipe	Till s/n. 65042 13001
14	Water Outlet Nipple	10472
15	Silicone Gasket	13006
16	Slide Keep Plate	10009
17	Sprayers Feeding Pipe	13005
18	Pump Suction Filter	20005
20	Fittings Locking Ring	Version 2 10405
21	Pump Suction/Delivery Pipe	Version 2 13136
22	Fitting of the Pump Suction/Delivery Pipes	Version 2 10404
23	Gasket for Pump Suction/Delivery Pipes	Version 2 13143
24	Pump Suction Pipe	Version 1 13003
25	Pump Delivery Pipe	Version 1 13002
26	Fixing Screw	Till s/n. 379503 20009
27	Flags ABS Support	Current Version 10529
28	Rod with Flags	Current Version C10533

Rev. 6 - 24/07/2007

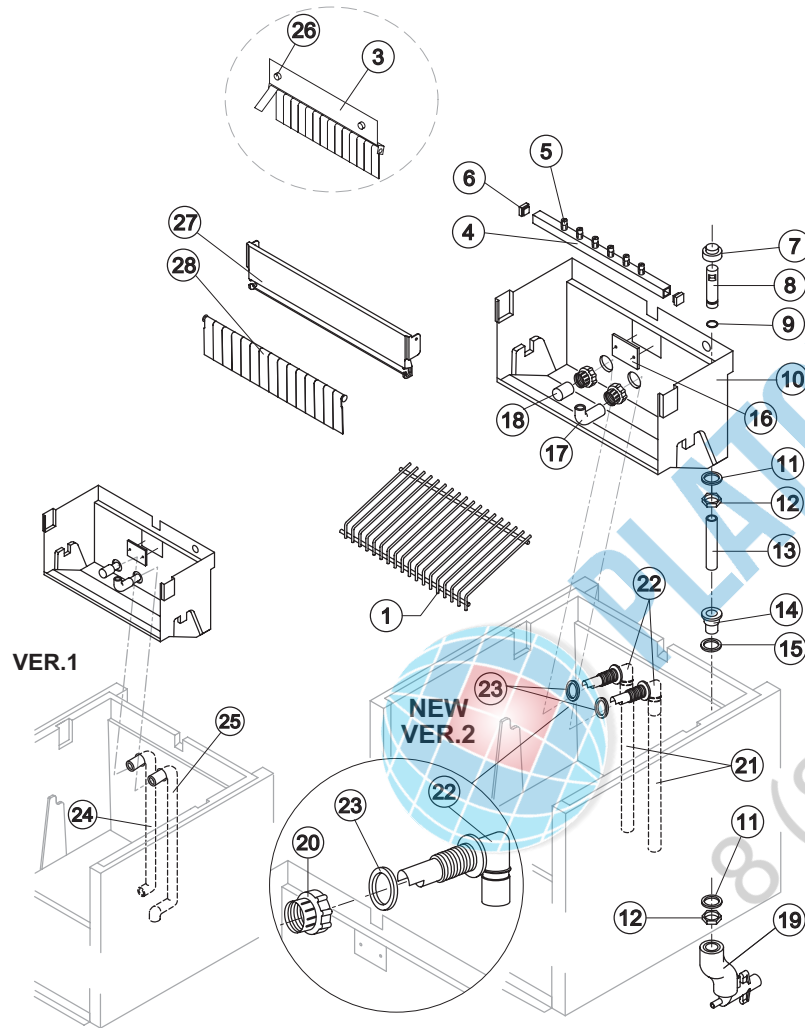

VER.1

NEW
VER.2

Ref. 1 - Ices Cube Slide

Kind of Cube	Code
18 g. (Standard)	D12001
33 g.	D12066
13 g.	D12046

Ref. 4 - Sprayers Bar Ass.

Kind of Cube	Code
18 g. (Standard)	C20028
33 g.	C20530
13 g.	C20289

Parts for Air Cooled Version Only

Ref.	Spare Description	Code
19	Discharges Manifold	C10006

Parts for Water Cooled Version Only

Ref.	Spare Description	Code
19	Discharges Manifold	C26452

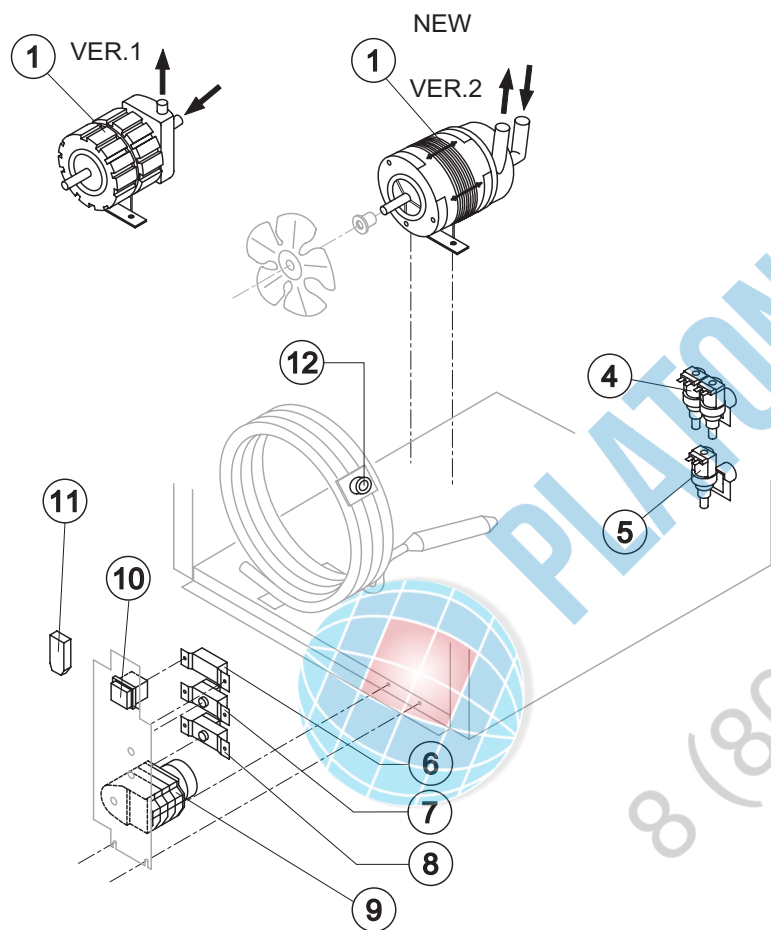

Common Parts

Ref.	Spare Description	Code
1	Pump	See Table
7	Bin Thermostat	R23005
8	Evaporator Thermostat	R23591
9	Timer	See Table
10	Green Light Switch (On-Off)	23327

Parts for Air Cooled Version Only

Ref.	Spare Description	Code
5	1 Way- Water Inlet Valve	See Table

Parts for Water Cooled Version Only

Ref.	Spare Description	Code
4	2 Ways Water Inlet Valve	See Table
6	Condenser Pressure Switch	See Table
11	Anti Radio Interference Filter	Only T11
12	Safety Thermostat	C23114

Ref. 1 - Pump

Tension	Version 1	Version 2
T11	23002	23377
T12	23002	23377
T13	23264	23663
T19	-	23663

Ref. 4 - 2 Ways- Water Inlet Valve

Tension	Code
T11	23542
T12	23542
T13	23592
T19	23592

Ref. 5 - 1 Way- Water Inlet Valve

Tension	Code
T11	23497
T12	23497
T13	23499
T19	23499

Ref. 6 - Cond. Pressure Switch

Tension	Code
T11	23175
T12	23175
T13	23175
T19	23680

Ref. 9 - Timer

Tension	18 g Cube	33 g Cube	13 g Cube
T11	23222	23248	23247
T12	23248	23780	23247
T13	23259	23786	23258
T19	23259	23786	23258